

**E-Z-GO Axle Lift  
2009.5 & Newer Gas (Kawi) TXT/WH  
Installation Instructions  
Part# 7226**



<b>ITEM</b>	<b>QTY</b>
A. FRONT AXLE	1
B. STEERING RISER	1
C. 2" X 1/2" BOLTS WITH LOCKNUTS	2
D. REAR LIFT RISERS	2
E. U-BOLTS WITH LOCKNUTS FOR REAR	4
F. WARNING LABEL	1
G. 2" X 1/2" BOLTS WITH LOCKNUTS FOR STEERING RISER	2

**FRONT INSTALLATION**

1. Jack up the front end of the cart and place it on jack stands. You will be installing larger wheels and tires so raise the cart high enough to accommodate for the additional height.
2. Remove the wheels and tires.
3. Remove the tie rod end at the spindle that attaches to the steering box.
4. Remove the spindles from the front axle. Clean and lubricate these bolts and bushings for the reinstallation of the spindles. The two stock mounting holes on the spindle of the passenger side needs drilled out to 1/2" for installation of the steering riser.
5. Remove the front axle from the leaf springs. Clean and lubricate the bolts for installation of the new axle.
6. Using the bolts from the old axle install JAKES front axle (Item A) to the leaf springs.
7. Install the spindles to the new front axle.

 *Always wear appropriate eye protection!*

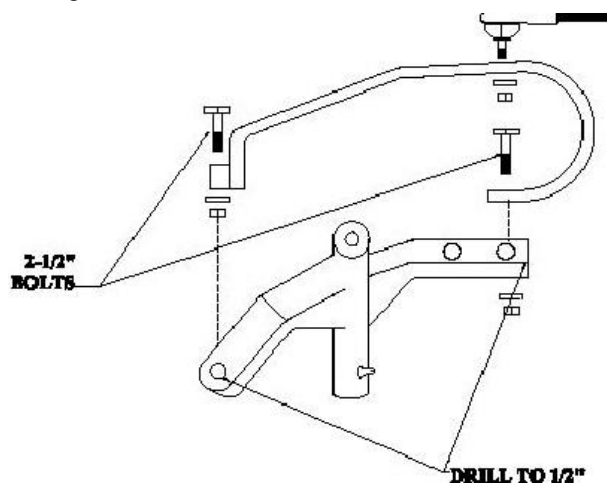

8. Install JAKES steering riser (Item B) to the passenger side spindle using the nuts and bolts provided (Item G).
9. Reattach the tie rod joints to the spindles. **NOTE: SOME E-Z-GO MODEL CARTS COME STOCK WITH A TIE ROD LONG ENOUGH! IF THE STOCK TIE ROD JOINTS DO NOT HAVE GREASE FITTINGS FROM WHEEL TO WHEEL YOU WILL NEED TO PURCHASE JAKE'S LONGER TIE ROD PART# 6206. IF YOU ORDERED YOUR KIT WITH THE LONGER TIE ROD INSTALL IT AT THIS TIME.**
10. Securely tighten all bolts.
11. Install JAKES recommended 22 x 11 x 10 wheels and tires with a 3 x 5" offset for maximum performance and stability. **NOTE: Your stock wheels and tires will NOT work!**
12. Take the cart off of the jack stands and lower the cart.
13. Drive the cart forward 10-20 feet and check the toe-in. (Proper toe-in should be approximately 1/8".)

### REAR INSTALLATION

1. Jack up the rear end of the cart and place jack stands on the frame in front of the springs. You will be installing larger wheels and tires so raise the cart high enough to accommodate the additional height.
2. Remove the wheels and tires.
3. Unhook brake cable tie straps from both sides of cart.
4. Unbolt the bottom of the shocks. Clean and lubricate these bolts for later use.
5. Remove leaf springs from cart. Clean and lubricate these bolts for later use. **NOTE: Keep the stock shock mount for reinstallation. The square bottom plates are not needed for reinstallation as shown in FIGURE 3.**
6. Place JAKES rear riser (Item D) on the axle as shown in the picture. **NOTE: There are holes in the front of each riser for the rear axle pin to be placed in as shown in FIGURE 2.**
7. Place the leaf springs on top of the rear risers. Using the stock hardware loosely mount the front of the rear leaf springs.
8. Place the stock shock plate on the top of the springs. Bolt the rear together as shown in the picture using the supplied u-bolts & nuts (Item E). Bolt the rear of the springs into place using the stock bolts as shown in FIGURE 1.
9. Attach the bottom of the shocks to the new location of the shock mounts using the stock bolts.
10. Bolt rear leaf springs to rear shackles.
11. Tie strap rear brake cables to a safe place on the leaf springs.
12. Securely tighten all bolts.
13. Install JAKES recommended wheel and tire size 22 x 11 x 10 wheels and tires with a 3 x 5" offset for maximum performance. **NOTE: Your stock wheels and tires will not work properly.**
14. Included is a warning label (Item F) which is to be placed on the steering column or another visible area and is to be read by all operators.

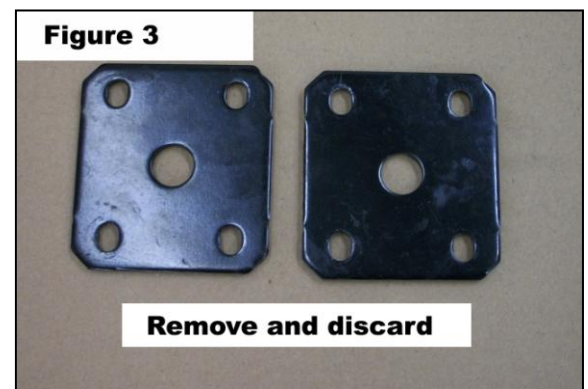
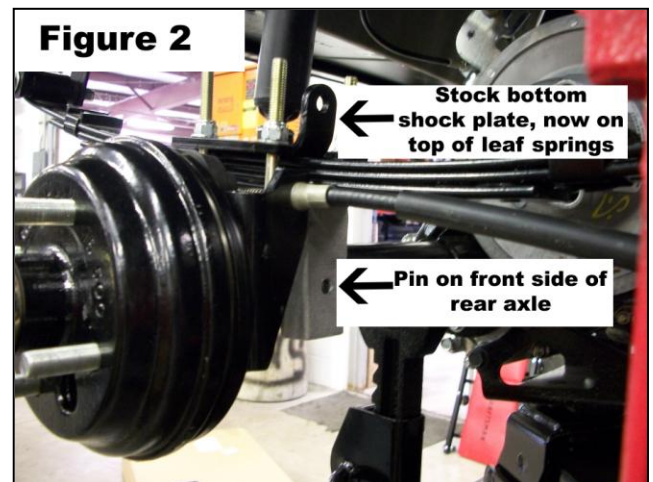
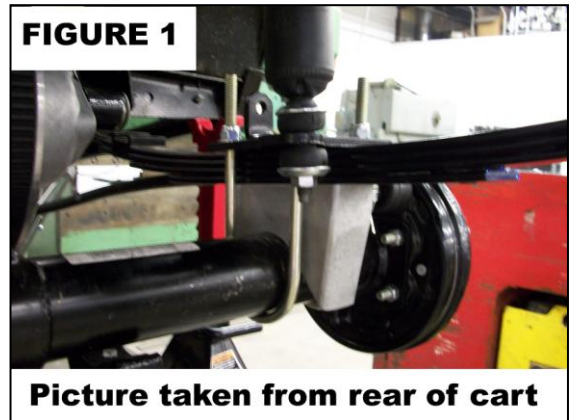

#### Indemnification And Insurance Agreement

High Performance Enhancement Kit purchaser assumes sole and entire responsibility for, and shall indemnify and save harmless Nivel LLC, from any and all claim, liability, responsibility, and persons or property that may be sustained in connection with the use of any product before or after purchase, including but not limited to high performance enhancement lift kits. The High Performance Enhancement Kit purchaser also shall indemnify Nivel LLC harmless with respect to any and all liability that may be incurred.

Golf Cars are recommended for use only by those aged 16 and older. Golf Cars can be especially hazardous to operate. Always remember that riding and alcohol/drugs don't mix. Never ride on public roads. Never carry more than two passengers (except shuttles and trams). Never engage in stunt driving. Avoid excessive speeds and be particularly careful on difficult terrain. Nivel LLC reserves the right, at any time, to discontinue or change specifications, prices, designs, features, models, or equipment without notice and without incurring any obligation.



866-405-2537

www.jakesliftkits.com

© Copyright Nivel LLC  
All Rights Reserved