

SGC



After installing this lift kit, the front wheels must be properly aligned. Failure to properly align the front wheels may result in decreased ability to control the Golf Cart which may result in a rollover or crash.

SGC

HD A-ARM LIFT KIT

FITS YAMAHA G29

HD A-ARM SUSPENSION INSTALLATION INSTRUCTIONS

YAMAHA DRIVE/G29

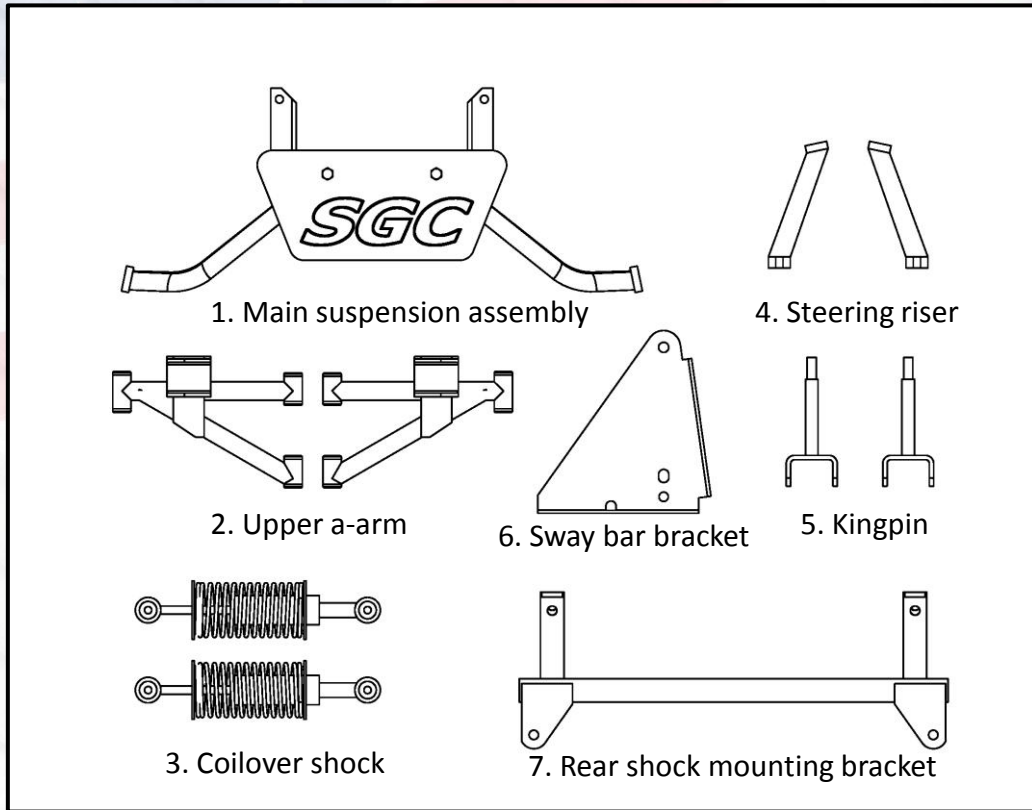

Used place	SEQ	Name	Specification	Qty
Upper A-Arm To Cart Frame	8	Hex Bolt	3/8-16*3	4
		Flat washer	3/8	8
		Lock Nut	3/8	4
Shock To Upper A-Arm	9	Hex Bolt	M12*70	2
		Flat washer	M12	4
		Lock Nut	M12	2
Spindle To Steering Riser	10	Hex Bolt	3/8-16*13/4	4
		Flat washer	3/8	8
		Lock Nut	3/8	4
Kingpin To Upper A-Arm	11	Hex Bolt	3/8-16*3 1/4	2
		Flat washer	3/8	4
		Lock Nut	3/8	2
	12	Heim Joint		2
Heim Joint	13	Hex Nut	1/2	4
Kingpin to Heim Joint	14	Nut	M12	2
Rear Suspension Shock mounting bracket	15	Hex Bolt	M10-60	2
		Flat washer	M10	4
		Lock Nut	M10	2
Sway Bar Bracket	16	Hex Bolt	M12-25	1
		Lock Nut	M12	1
Sway Bar Bracket	17	Hex Bolt	M10-90	1
		Flat washer	M10	2
		Lock Nut	M10	1
	18	Drill Bit	11	1

HD A-ARM SUSPENSION INSTALLATION INSTRUCTIONS YAMAHA DRIVE/G29

After installing this lift kit, the front wheels must be properly aligned. Failure to properly align the front wheels may result in decreased ability to control the golf cart which may result in a rollover or crash.

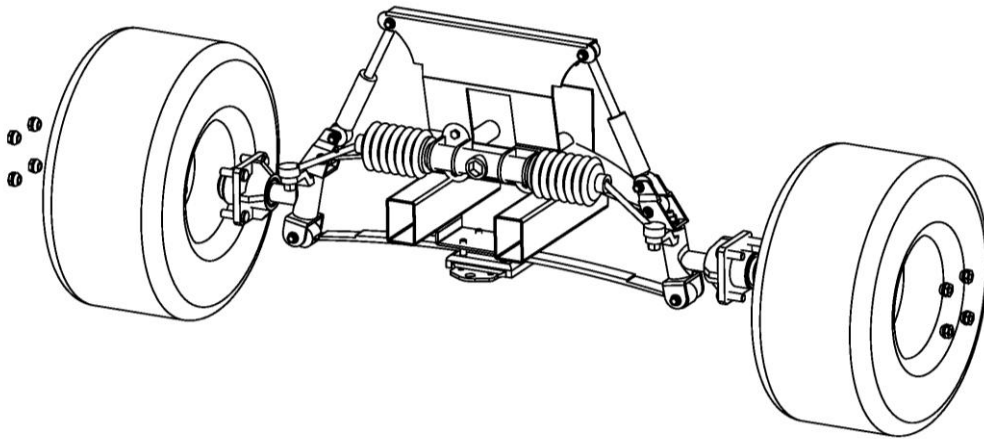

1. Engage park brake. Raise cart with lift and support with jack stands. Remove front wheels. Remove front bumper. Retain hardware.

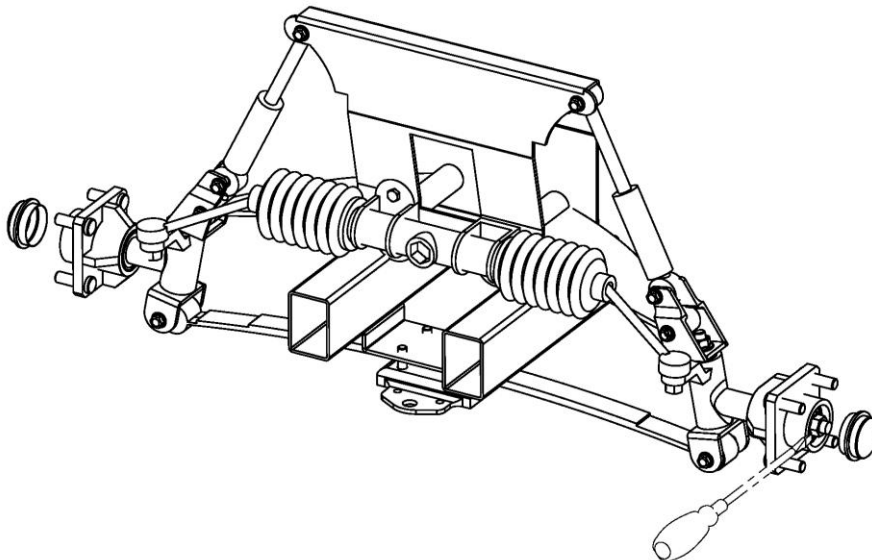

2. Remove dust cover, cotter pin and hub. Retain hardware.

HD A-ARM SUSPENSION INSTALLATION INSTRUCTIONS

YAMAHA DRIVE/G29

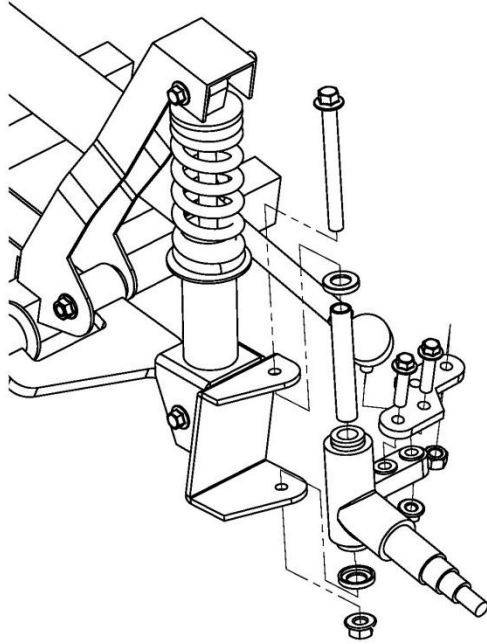

3. Remove spindle from knuckle bracket.

Disconnect ball joint from the spindle.

Remove inner tube from inside the spindle.

Retain the spindle and the nut that connects tie rod end.

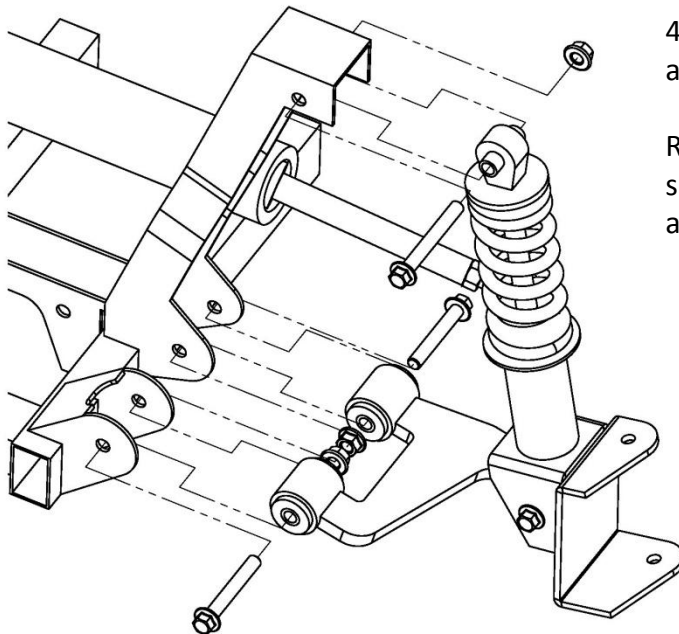

4. Remove bolts from control arm assemblies.

Remove upper bolts from shocks to remove control arm assembly.

HD A-ARM SUSPENSION INSTALLATION INSTRUCTIONS

YAMAHA DRIVE/G29

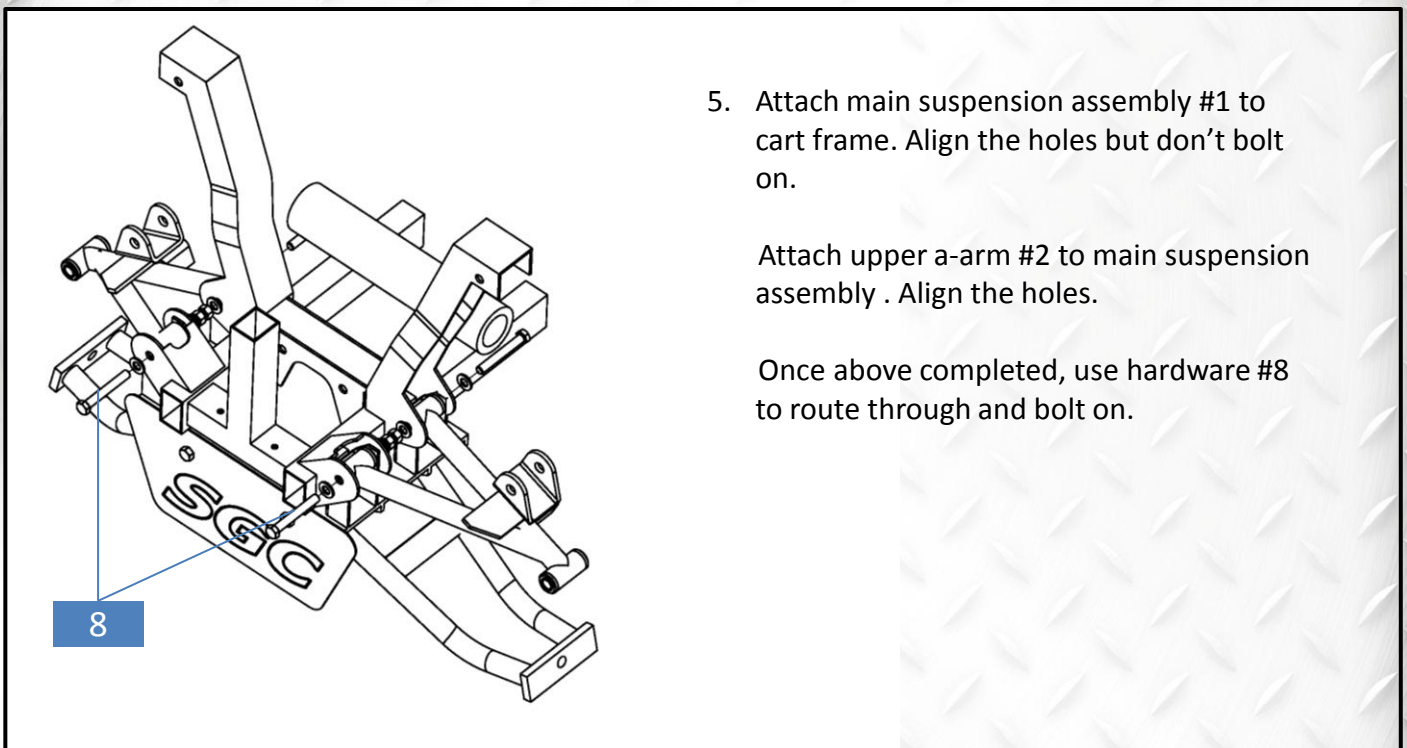
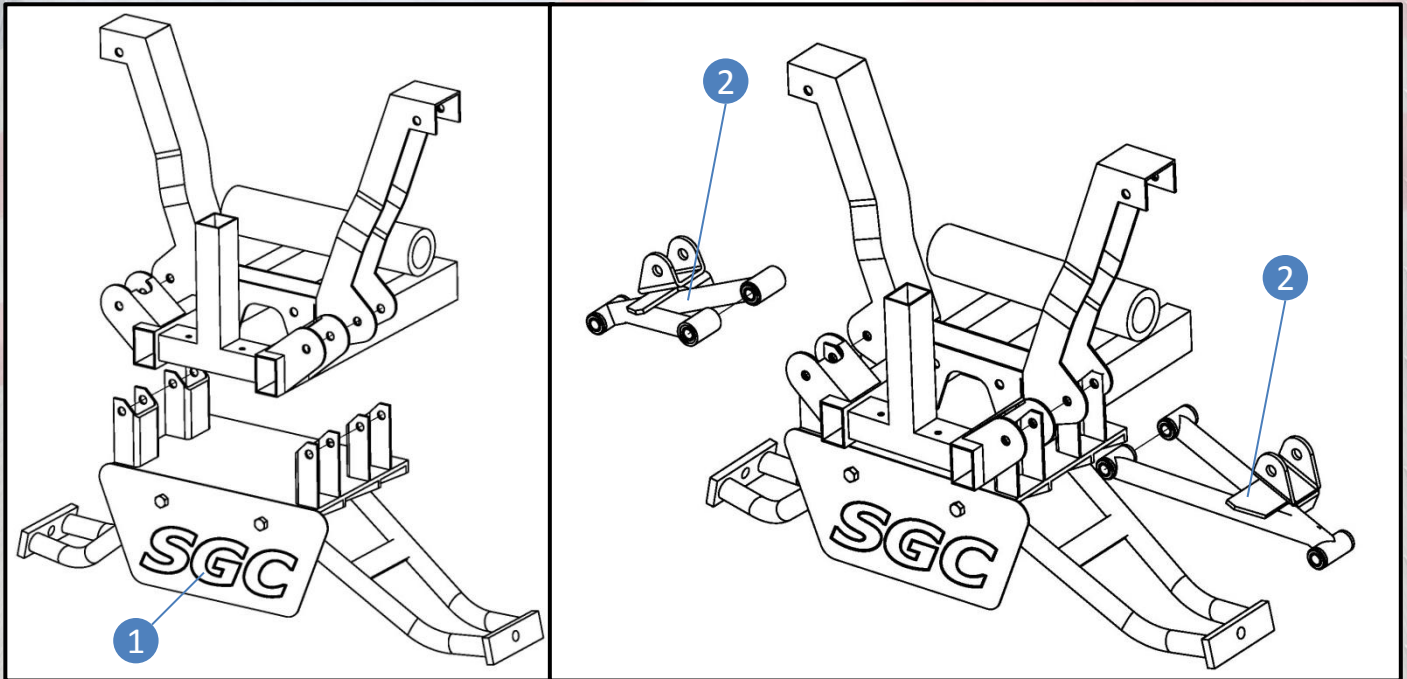

HD A-ARM SUSPENSION INSTALLATION INSTRUCTIONS

YAMAHA DRIVE/G29

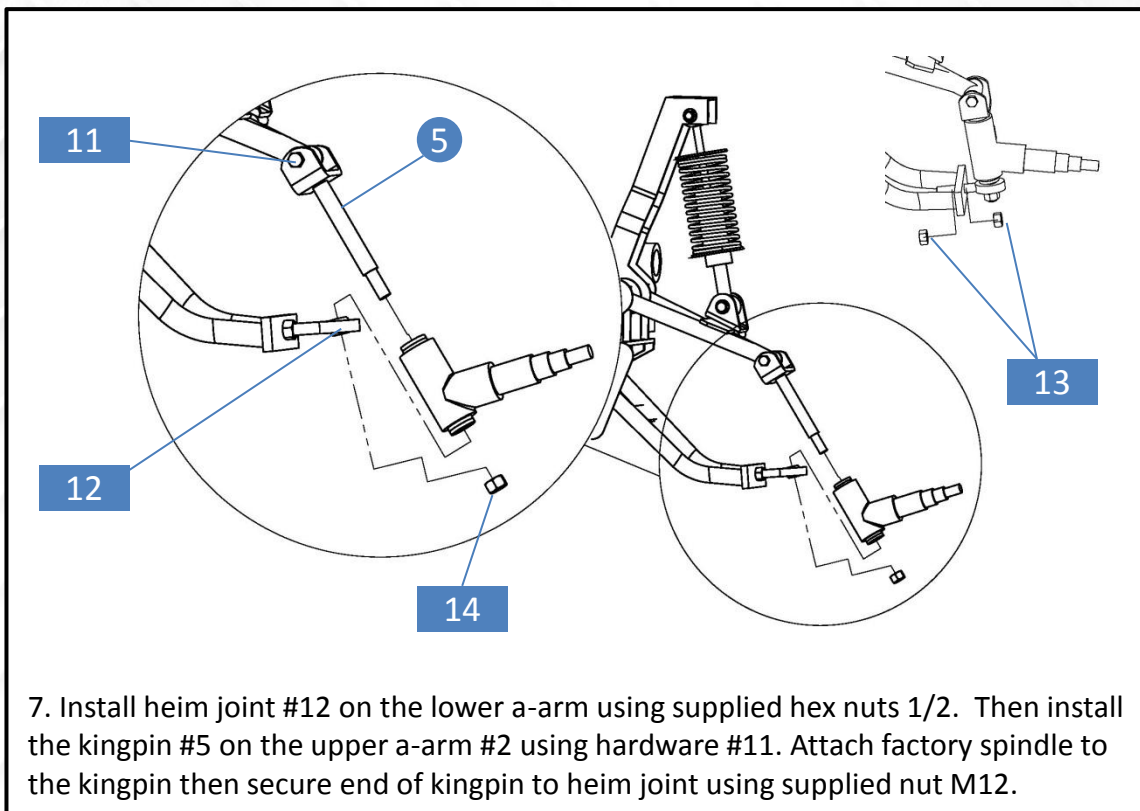
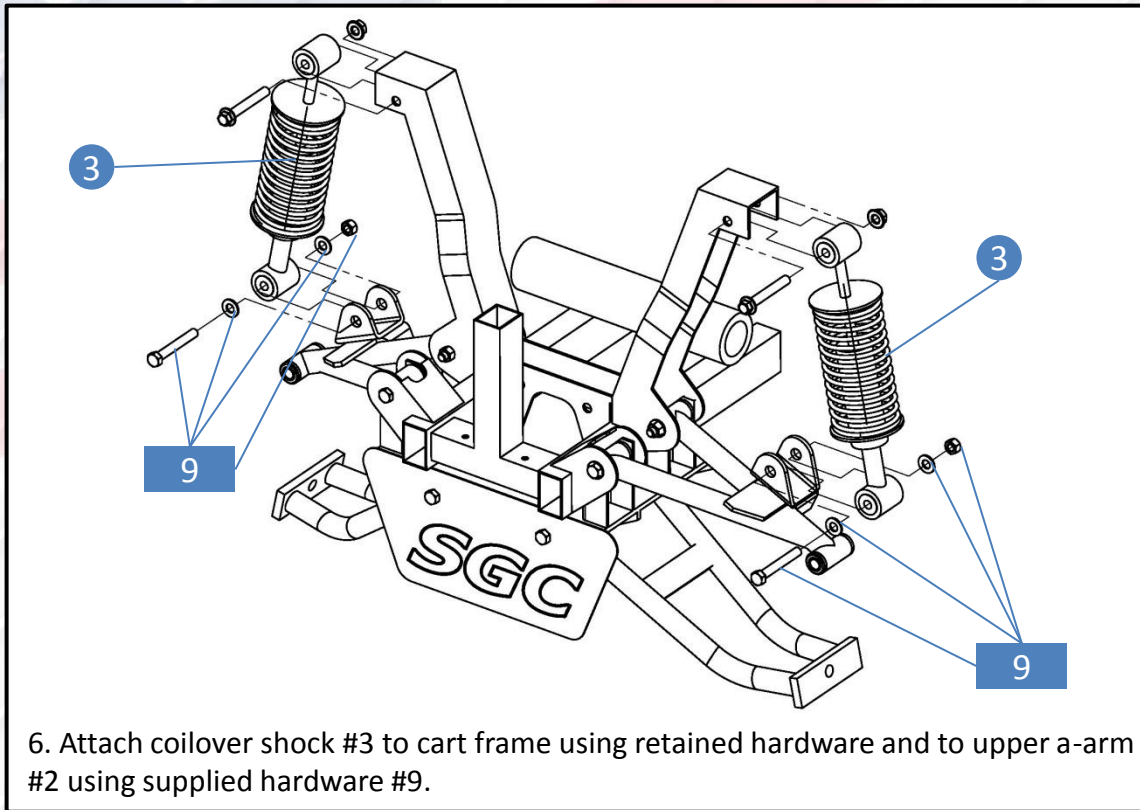

HD A-ARM SUSPENSION INSTALLATION INSTRUCTIONS

YAMAHA DRIVE/G29

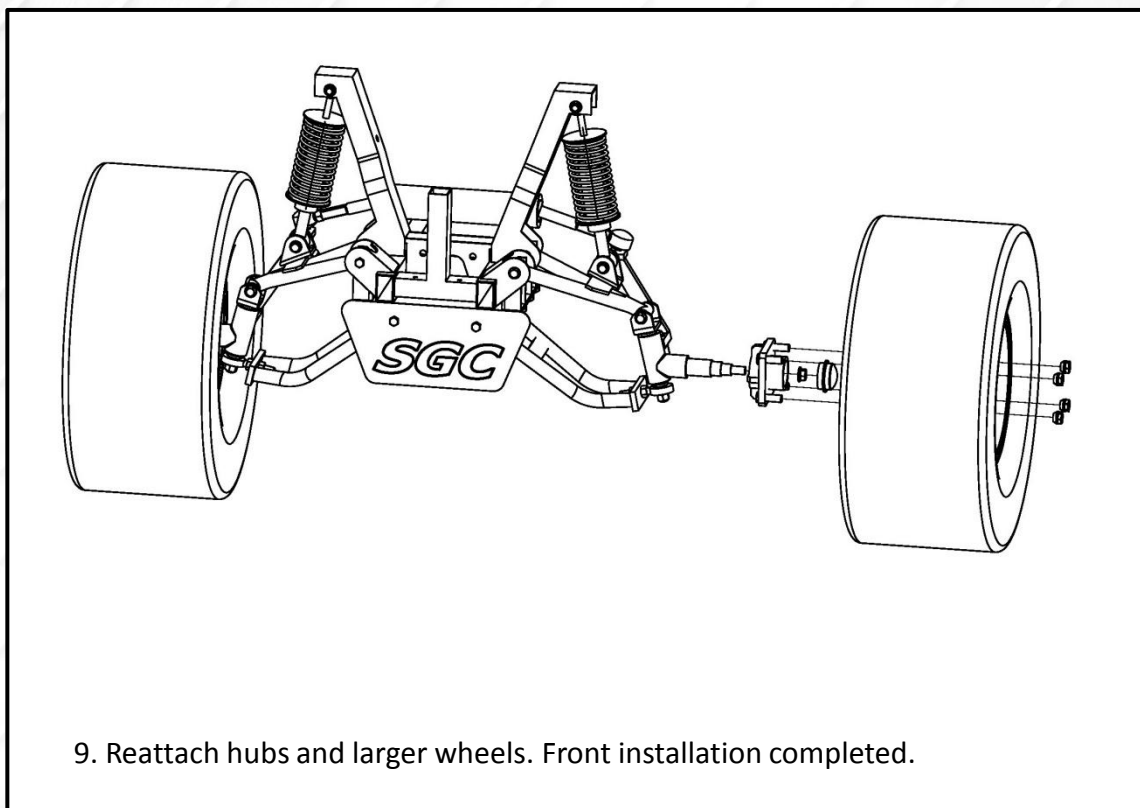
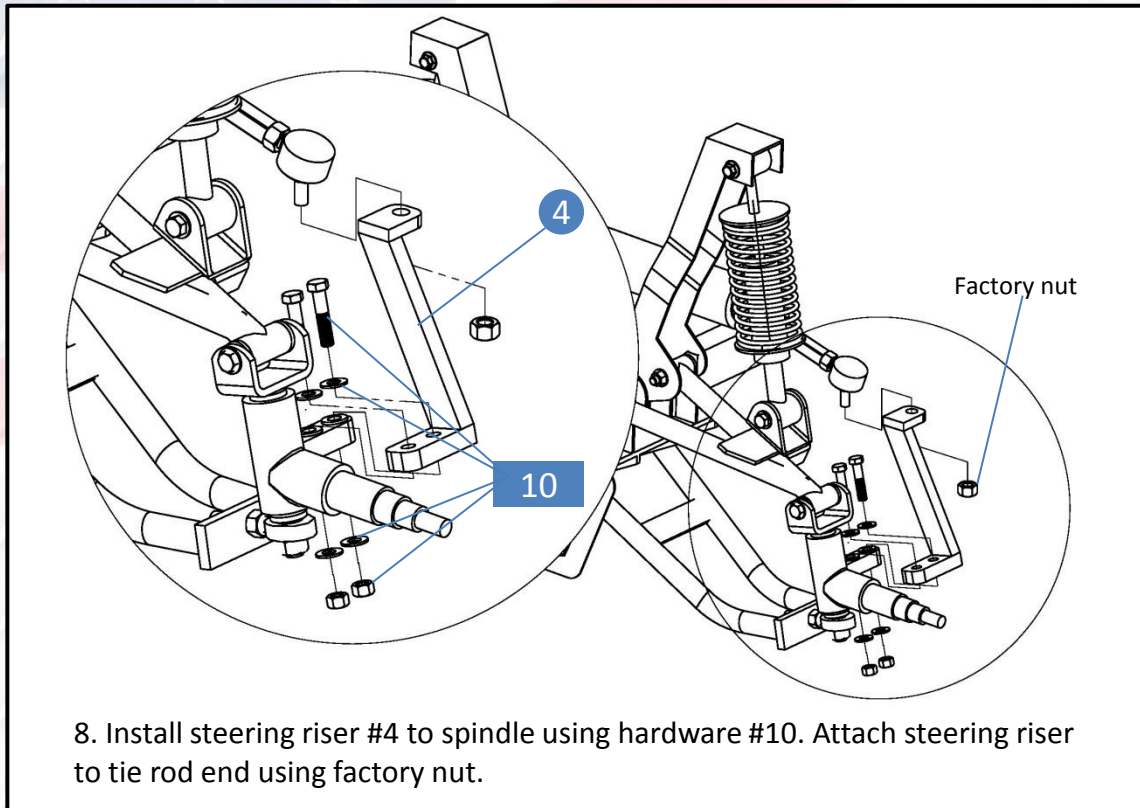

HD A-ARM SUSPENSION INSTALLATION INSTRUCTIONS

YAMAHA DRIVE/G29

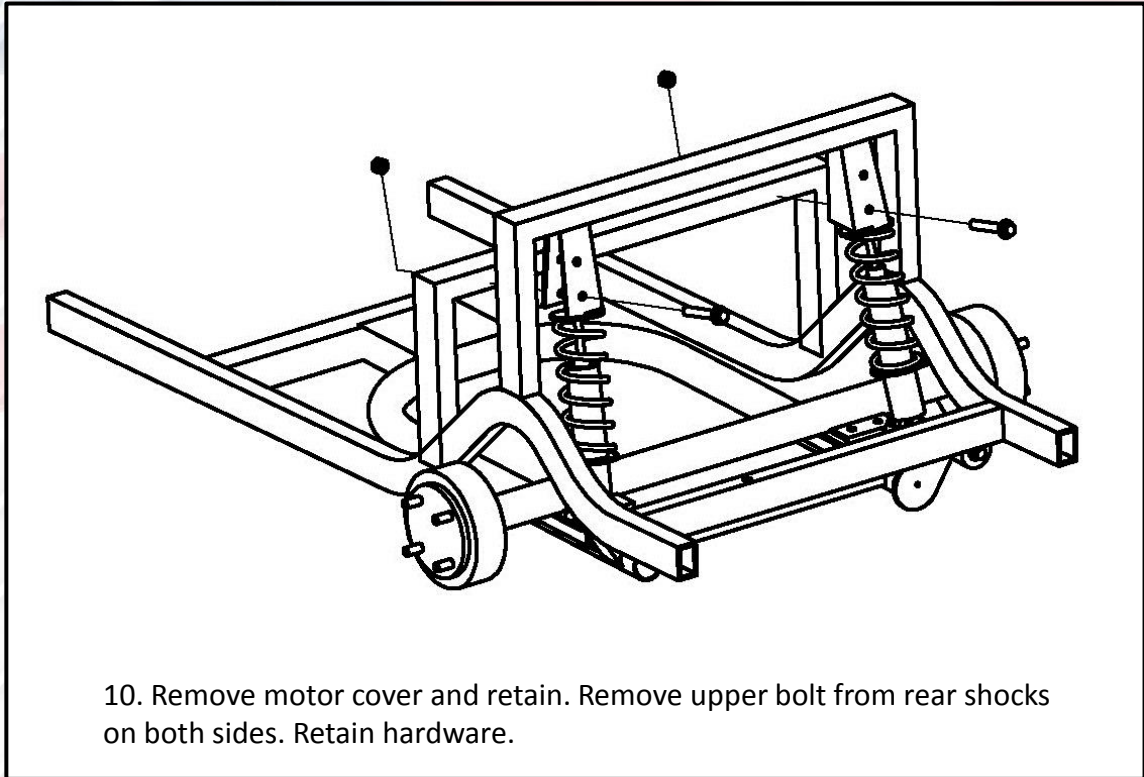

10. Remove motor cover and retain. Remove upper bolt from rear shocks on both sides. Retain hardware.

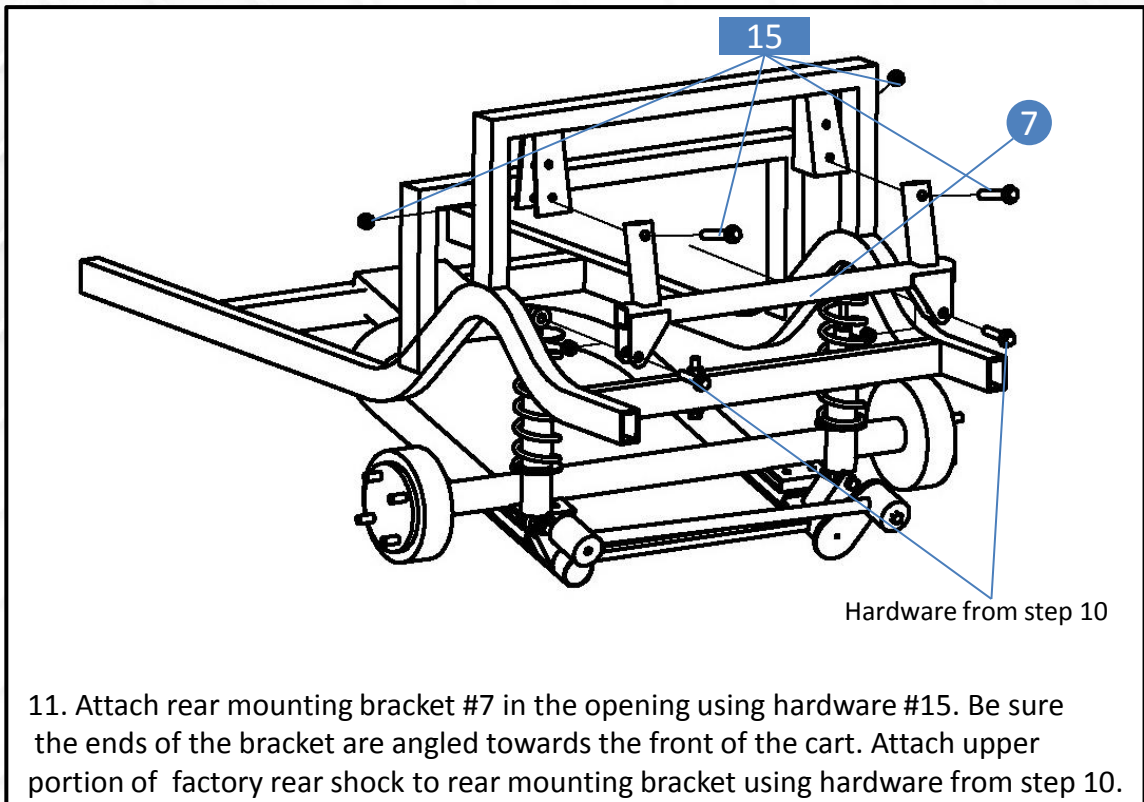

11. Attach rear mounting bracket #7 in the opening using hardware #15. Be sure the ends of the bracket are angled towards the front of the cart. Attach upper portion of factory rear shock to rear mounting bracket using hardware from step 10.

HD A-ARM SUSPENSION INSTALLATION INSTRUCTIONS YAMAHA DRIVE/G29

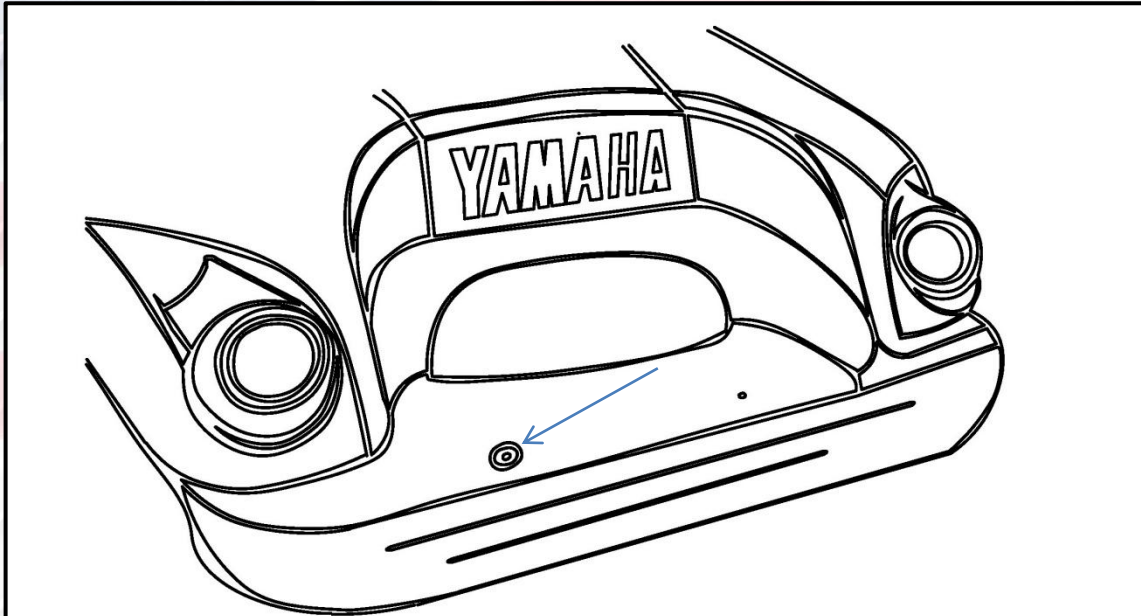

12. Drill hole through the bagwell in the location shown. Depending on manufacturing year, a rivet or bolt should be removed first. Be sure to drill straight down through entire frame. Drill bit provided.

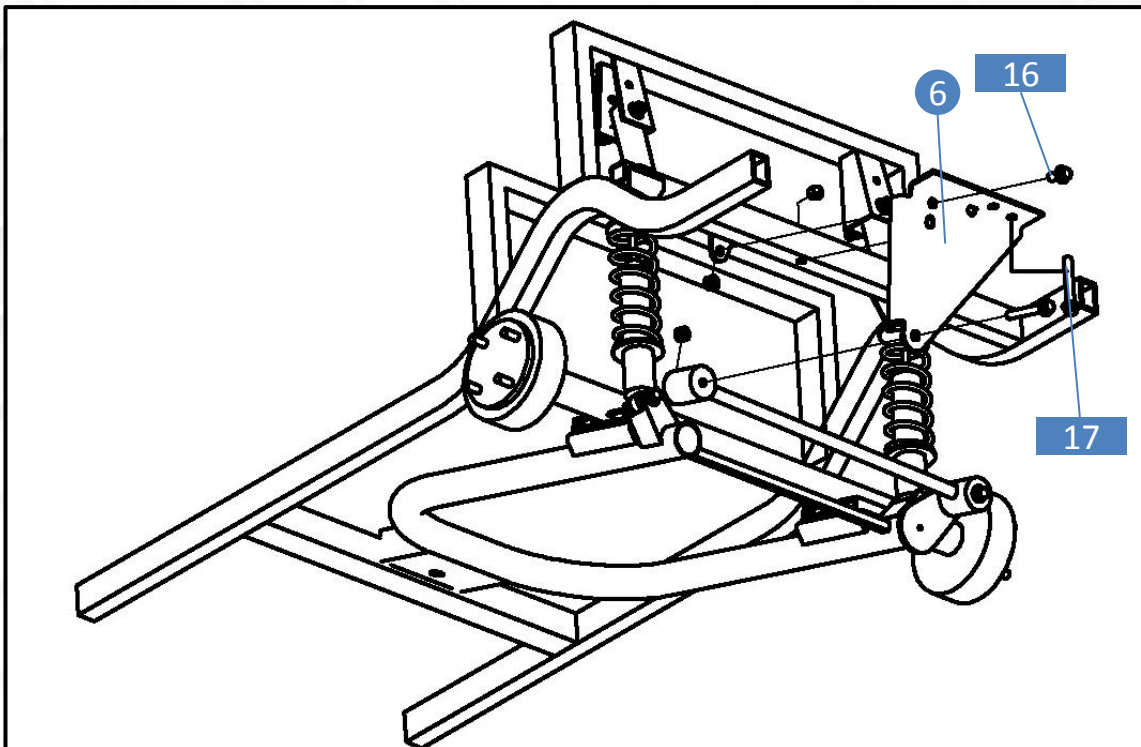

13. Attach sway bar bracket #6 using hardware #16, then M10-90 from hardware #17 from the drilled hole down to top. Attach sway bar to sway bar bracket using factory hardware.

HD A-ARM SUSPENSION INSTALLATION INSTRUCTIONS YAMAHA DRIVE/G29

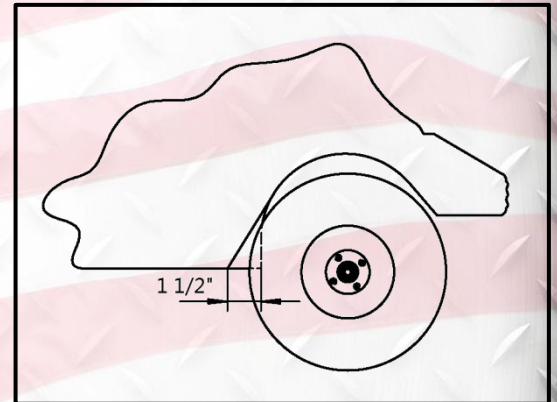
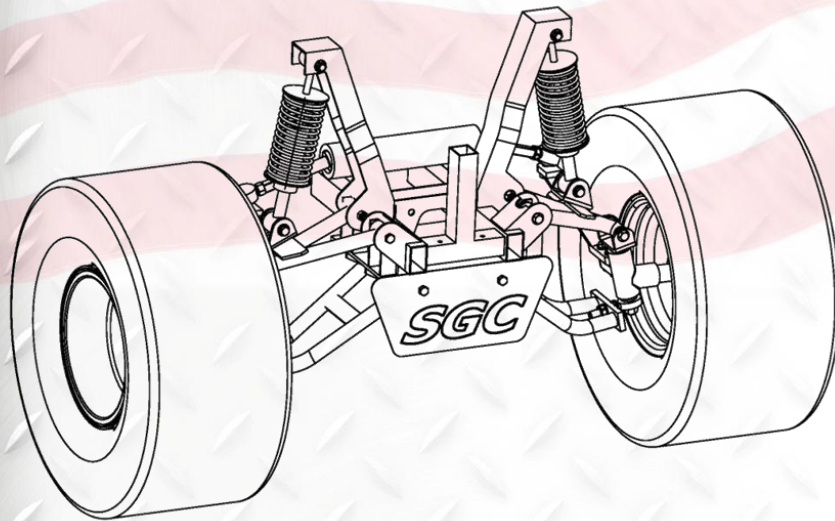

Rear Inner fenders & rockers will need heated, reformed or cut for tire clearance

After installing this lift kit, the front wheels must be properly aligned. Failure to properly align the front wheels may result in decreased ability to control the golf cart which may result in a rollover or crash.

IMPORTANT: Both camber and toe must be adjusted on this model.

Once installation is complete and the wheels have been reinstalled, roll the cart forward 5-6 feet.

Ensure the wheels are pointing straight forward. To adjust toe, find a common point to measure from on the inside front and inside rear of the front tires. Adjust until the front measurement is $1/4''$ to $3/8''$ greater than the rear measurement.

To adjust for proper camber, use a framing square, level or some other means of verifying that the tire is at a 90 degree angle to the ground.

To adjust toe-in/toe-out, loosen nut on tie rod end. Adjust using a wrench to desired alignment.

IMPORTANT: Ensure that after this adjustment, both wheels toe out from the cart's center line equally.

To adjust camber (the vertical tilt of the wheels) to 90 degree using the two nuts on the bottom heim joint.

If adjusting the camber to 90 degrees is not possible using only the adjustment on the bottom heim joint, then the top heim joint must be disconnected from the spindle and rotated as necessary to achieve the correct camber.

IMPORTANT: Exposed tie rod threading should be equal on both tie rods. Be sure to retighten all adjustment points after adjustments are made. Once tightened, roll the cart back 5-6 feet and then forward again to check.



RETURN MERCHANDISE AUTHORIZATION

Dear Valued Customer,

Thank you for choosing Steeleng Golf Cart Accessories for your golf cart needs.

We apologize for the issues you are having with your purchase. We strive to offer the absolute best quality at the absolute best price.

To best serve you, we do need a little information to help process your return and/or exchange faster.

Please complete the following and include this entire form with your return.

Name

Shipped To Address

STATE

ZIP

Purchased with: eBay Direct Phone Order

This is for EXCHANGE REFUND

Please describe reason for return:-

Our Return Address:
Steeleng Golf Cart Accessories
3309 Laurens Road,
Greenville, SC 29607
Tele: 864-675-1103

For Office Use Only:

Received By: _____

Date _____

Refund Amount _____

Exchange Issued _____

**Steeleng Golf Cart Accessories reserves the right to charge a 15% restocking fee for all returned and/or exchanged items.