



E-Z-GO TXT - Phoenix-TX

PHOENIX-TX™

BODY & LIGHT KIT FOR E-Z-GO TXT

TABLE OF CONTENTS:

- Step 1** - Prebuild Car Prep / Light Kit Components List
- Step 2** - Route Bucket Harness to Front and Rear of Chassis
- Step 3** - Install Micro Switch and Delay Timer
- Step 4** - Install Dash Harness and Headlight Harness
- Step 5** - Prepare and Install Phoenix Front Cowl
- Step 6** - Install Optional Sentry Dash
- Step 7** - Install Rear Body
- Step 8** - Install Optional Pilot Steering Wheel
- Step 9** - Final Assembly

IMPORTANT: Do not fully tighten hardware until instructed. Read through all instructions before beginning installation.

WARNING: DO NOT CONNECT THE LIGHT KIT WIRING HARNESS TO MORE THAN 16 VOLTS OR PERMANENT DAMAGE TO HARNESS AND LIGHTS WILL OCCUR.

Prior to servicing, turn the key switch OFF, remove the key, and place the Forward / Reverse handle in Neutral position. Block all wheels when servicing the vehicle.

Make sure all wiring and wire harnesses are properly routed and secure before any initial testing is done. Position all electrical components in areas that are protected from moisture and/or salt air.

ALL ELECTRIC VEHICLES:

To avoid unintentionally starting the vehicle, disconnect the batteries as shown on top right.

NOTE: For models with a TOW/RUN switch, place the switch in the TOW POSITION before disconnecting or connecting the battery cables.

ELECTRIC VEHICLES WITH SPEED CONTROLLERS:

After disconnecting the batteries, discharge the controller capacitors as follows:

- Turn key to ON and place the forward/reverse handle in REVERSE.
- Slowly depress accelerator pedal and keep depressed until the reverse warning buzzer can no longer be heard. When buzzer stops sounding, the controller capacitors are discharged.

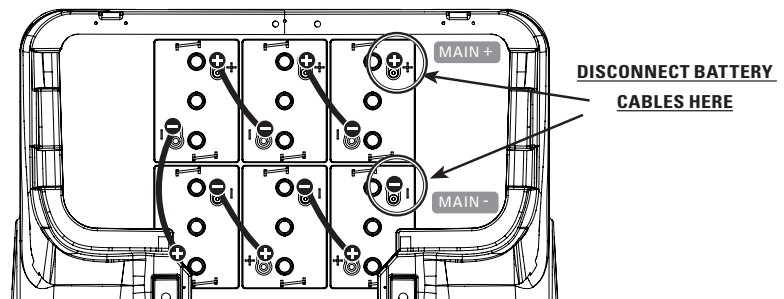

PREBUILD CAR PREP

STEP 1 PREPARE CAR FOR INSTALLATION

Remove the following:

- Factory Top
- Front Frame
- Factory Top Rear Supports
- Windshield
- Sweater Basket
- Seat Back Supports
- Front Seat Bottom
- Front and Rear Colored Body Panels
- Side Rocker Panels
- Rear Bumper



LIGHT KIT COMPONENTS LIST

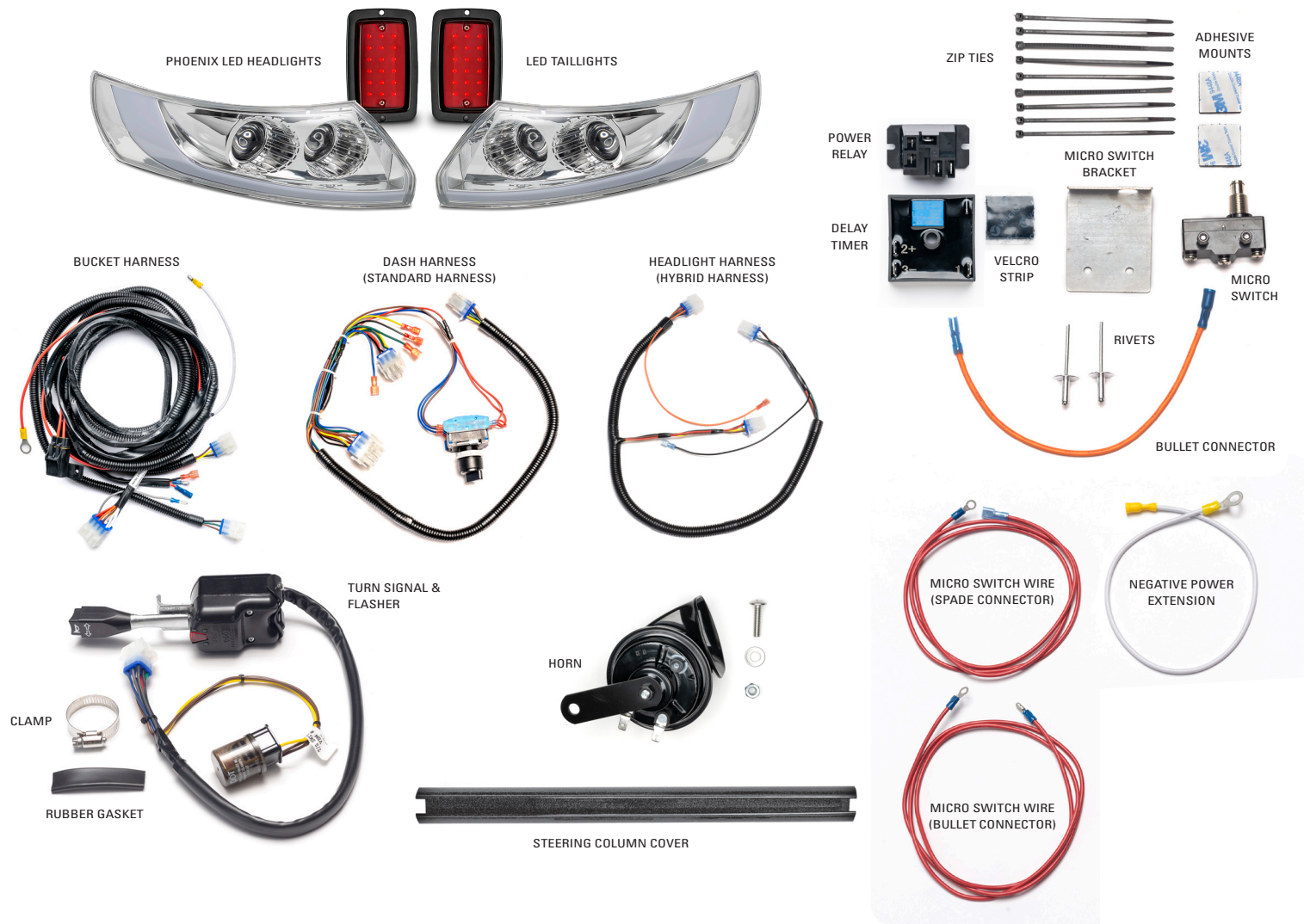

STEP 2.2 ROUTE BUCKET HARNESS TO FRONT

- A.** Route the Bucket Harness 12-Pin Connector and Delay Timer Wires **(1&2)** to the front of car, by inserting them between battery cage and floorboard on the Driver side. Pull the excess Delay Timer Wires **(2)** back towards fender well and leave hanging for use later.
- B.** Pull the 12-Pin Connector **(1)** all the way to front of car and rest on front tire. Make sure there is enough length to reach around behind the dash compartment. Use Cable Ties to secure Harness along channel under the car, beside the Brake Pedal Rocker Arm **(6)**.
- C.** Connect the White Negative Wire extension **(7)** to the White Negative Wire protruding from Harness (Bullet connection).

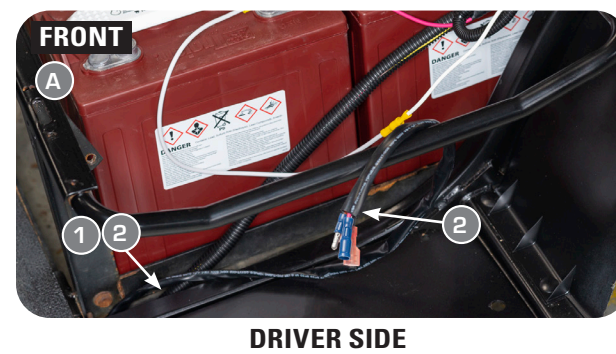

STEP 2.3 ROUTE TAIL LIGHT HARNESS TO REAR, SECURE, AND CONNECT ADAPTERS

- D.** Route the Passenger Tail Light Harness **(4)** to the rear on Passenger side and the Driver Tail Light Harness **(5)** to the rear of car on Driver side, and secure with Cable Ties.



ROUTE BUCKET HARNESS TO FRONT & REAR OF CHASSIS

STEP 2.1 BUCKET HARNESS LAYOUT

Bucket Harness:

- 1.** 12-pin connector routes to Dash Harness
- 2.** Wires for Micro Switch & Delay Timer
- 3.** Inline Fuse and Harness power supply
- 4.** Routes to Passenger Tail Light
- 5.** Routes to Driver Tail Light (has protruding negative power wire)

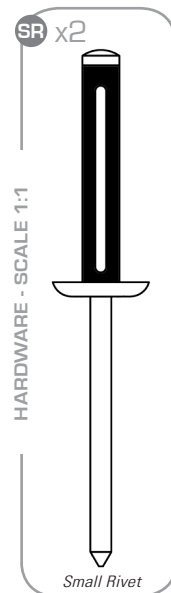
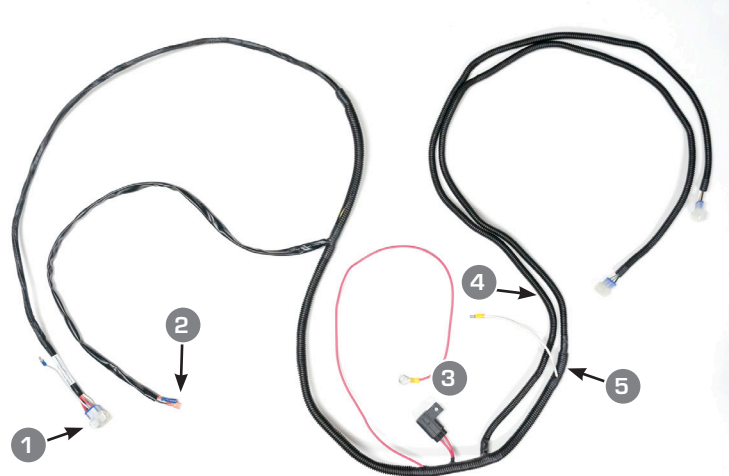

INSTALL MICRO SWITCH & DELAY TIMER

STEP 3.1 INSTALL MICRO SWITCH

- A.** Connect the two Red Micro Switch Wires **(1&2)** to the outside screws on the Micro Switch. Route the Red Wires back to the battery compartment, following the Bucket Harness **(from Step 2.2-A)**.
- B.** Remove the top Hex Nut from Micro Switch. Insert Micro Switch button through hole in Micro Switch Bracket. Reinstall the Hex Nut.
 - ****Make sure Parking Brake is NOT engaged**** and position Micro Switch Bracket under Floorboard, making sure the button on Micro Switch is completely pressed/activated against the Brake Rocker Arm **(6)**.
 - Mark Bracket hole locations and drill 1/8" holes through Floorboard to install Bracket using Small Rivets **(SR x 2)**.

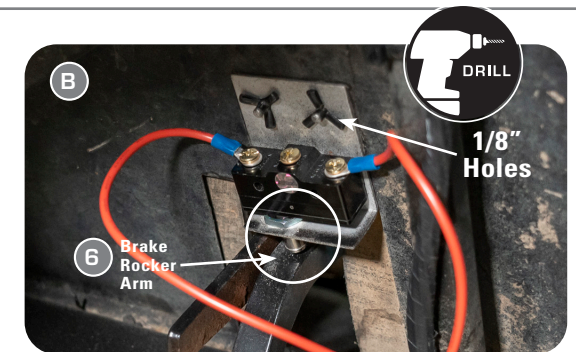
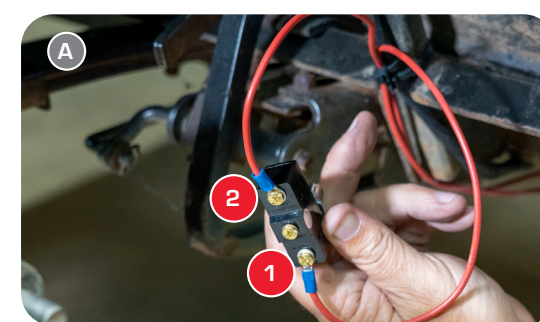

INSTALL MICRO SWITCH & DELAY TIMER (CONTINUED)

STEP 3.2 INSTALL DELAY TIMER

- Attach the Delay Timer to the Chassis Frame on the Driver Side, where the Bucket Harness is located. Make sure the Power Relay is oriented with the 2 blade connectors closest to each other, in the upper right corner.

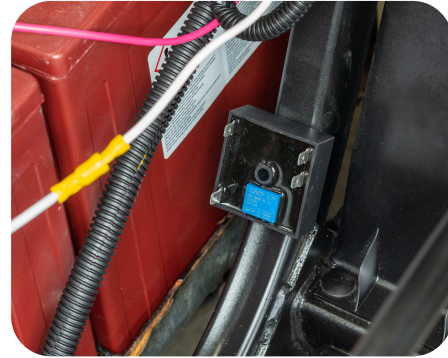

STEP 3.4 SECURE EXCESS WIRING

- E. Gather the excess Wiring Harness and use cable ties to secure next to batteries
- F. Gather the excess Wiring Harness routed to rear of car and use cable ties to secure to car frame

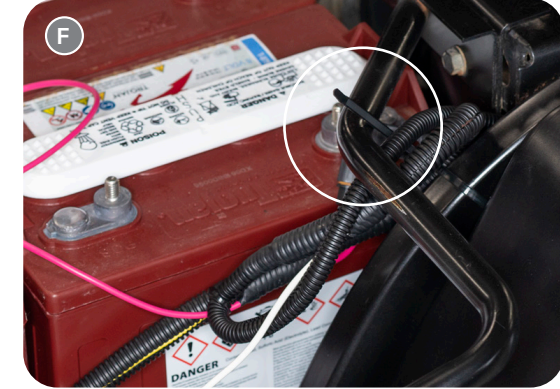

STEP 3.3 CONNECT MICRO SWITCH & DELAY TIMER WIRING

C. Locate the Bucket Wire Harness end that has the exposed 3 wires — Black, Red, & Orange (from Step 2.2-A).

D. Next, connect the Delay Timer to the Micro Switch and Bucket Harness 3-Wire section:

Note. The 2 Red wires were previously installed O-Ring end to the Micro Switch (1-2) in a previous step (from Step 3.1-A).

- From the Micro Switch, connect the Red wire Spade (3) to Pin 3- on the Delay Timer (3)
- From the Micro Switch, connect the Red wire Bullet Male (4) to the Bucket Harness Red Bullet Female (4)
- Connect the Orange Jumper wire Bullet Female (5), to the Bucket Harness Orange Bullet Male (5)
- Connect the Orange Jumper wire Spade (6), to Pin 1 on the Delay Timer (6)
- Connect the Bucket Harness Black wire Spade (7), to Pin 2+ on the Delay Timer (7)

MICRO SWITCH & DELAY TIMER WIRING

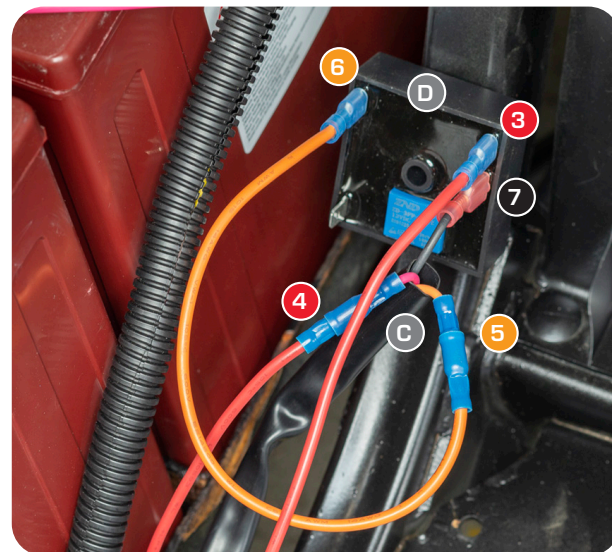
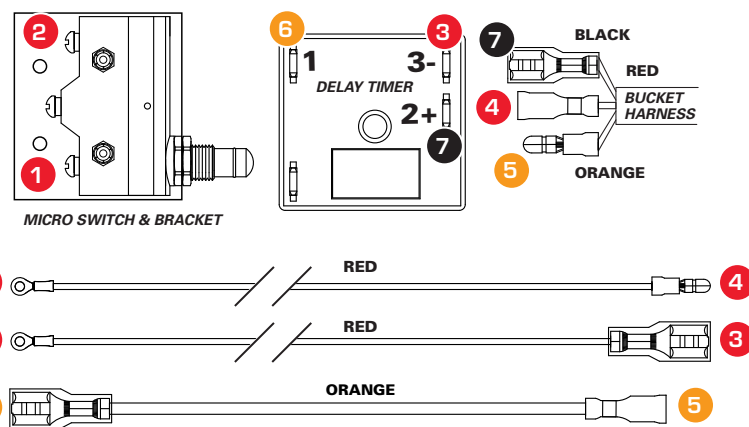

INSTALL DASH HARNESS & HEADLIGHT HARNESS

STEP 4.1 INSTALL DASH HARNESS AND HEADLIGHT HARNESS

Dash Harness:

1. 12-pin Connector connects to Bucket Harness
2. 6-pin Connector to Headlight Harness
3. 3-Way Light Switch
4. Connects to Turn Signal
5. 4 Wires connect to Power Relay

- A. Insert the Dash Harness into dash compartment and route the 12-pin Connector (1) and 6-pin Headlight Connector (2) to the front of car. Connect the Dash Harness 12-pin Connector to the Bucket Harness Connector (6).
- B. Leave the 3-Way Light Switch (3), Turn Signal Connector (4) and Power Relay Wires (5) accessible in the Dash Compartment.

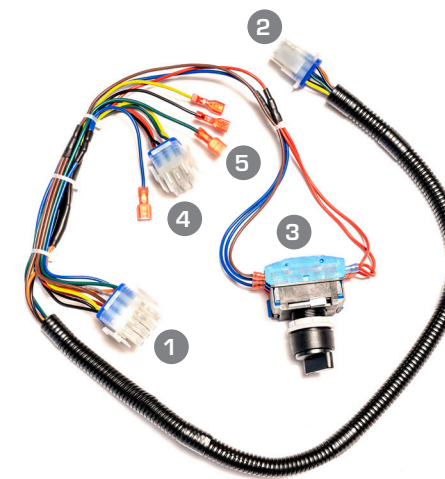

DASH HARNESS (STANDARD HARNESS)

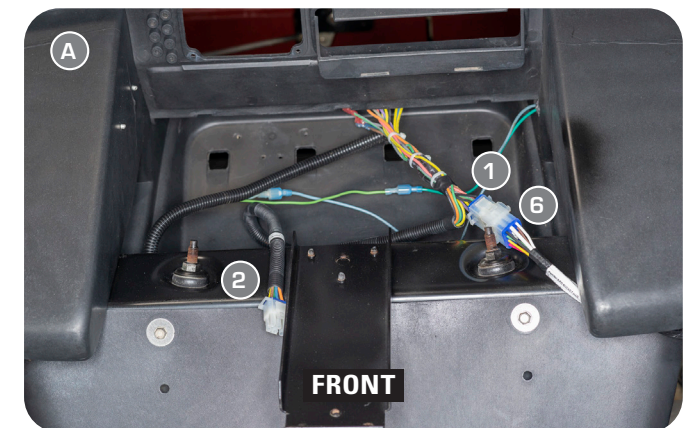

STEP 4.2 CONNECT HEADLIGHT HARNESS TO DASH HARNESS

Headlight Harness:

- 1. Connects to Dash Harness 6-pin Connector
- 2. Connects to Driver Headlight
- 3. Connects to Passenger Headlight
- 4. Connects to Horn

- Connect the Headlight Harness (1) to the Dash Harness 6-pin Connector (5).
- Route the Headlight Harness to the Driver (2) and Passenger (3) sides and secure with cable ties (6).

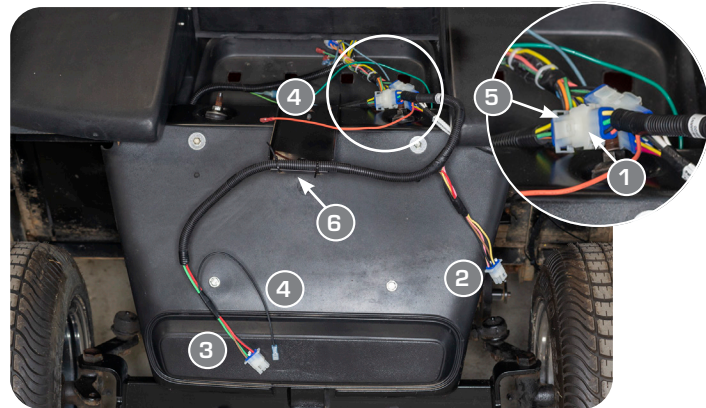
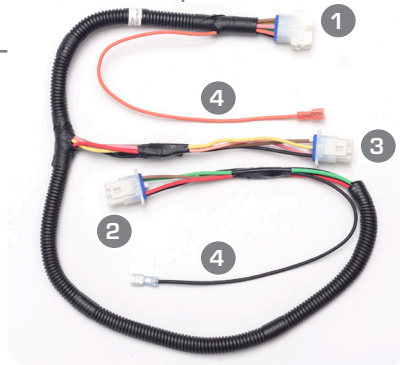

STEP 4.3 MOUNT HORN

- Mount the Horn to the support frame, using the attached bracket and provided hardware.



STEP 4.4 CONNECT HORN POWER

- Connect the Horn Power Wires to the horn.



STEP 5.3 INSTALL HEADLIGHTS - DO NOT FULLY TIGHTEN

- Insert Headlights into Phoenix front cowl and LOOSLY secure with washers and nuts (LN x 4).
- ** Hand-tighten the nuts ONLY - Leave loose until Grille is installed ****



STEP 5.4 INSTALL GRILLE

- Insert Grille into front cowl and secure 4 bolts with washers and nuts (LN x 4). Hand-tighten enough to secure Grille position.



STEP 5.5 CLOSE ANY GAPS AND SECURE

- Slide Headlight and/or Grille to close any noticeable gaps.
- Fully tighten all hardware — **Do not overtighten or damage may occur**

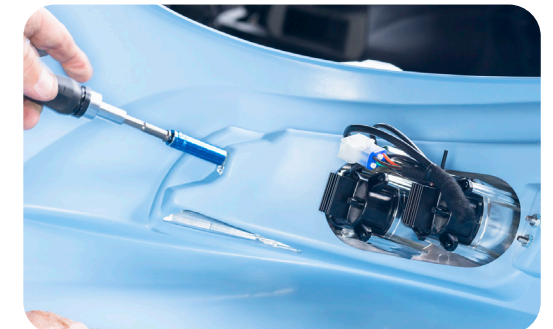

PREPARE AND INSTALL PHOENIX FRONT COWL

STEP 5.1 INSTALL GRILLE INSERT

- Install the Grille Insert into the Grille Frame using the provided screws (GS x 10).



STEP 5.2 REMOVE PROTECTIVE FILM

- Before installing Grille and Headlights, remove the protective film from the recessed area of Phoenix front cowl where indicated.



HARDWARE - SCALE 1:1

LN x8		GS x10	
#10 Flat Washer - #10-24 Nyloc Nut		#10 Flat Sheet Metal Screw	



STEP 5.6 INSTALL MOUNTING BRACKETS

- Insert Front Cowl Brackets (FB x7) under the Front Cowl, along the back top edge, using the pre-drilled holes. Attach the Brackets with Extra Small Rivets (ES x7) as shown.

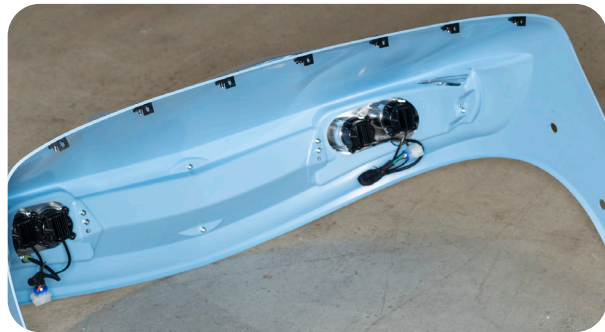
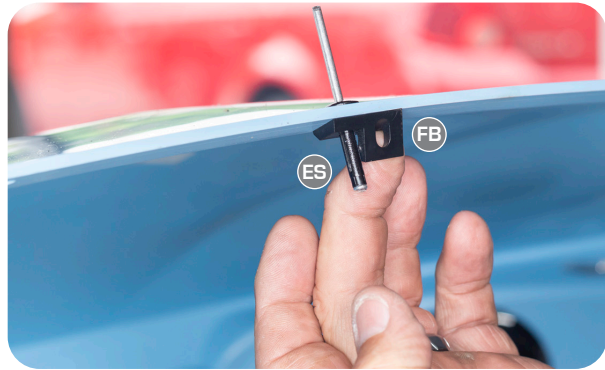

STEP 5.7 ATTACH COWL TO DASH FRAME

- Position Front Cowl along Dash Frame and align Front Cowl Brackets to holes in Dash Frame. Attach Cowl using Medium Rivets (SR x5).



STEP 5.8 ATTACH COWL BOTTOM

- Attach the bottom of Cowl using a Small Rivet (SR x2). Repeat for opposite side.



STEP 5.9 CONNECT HEADLIGHTS

- Connect Headlights to Headlight Harness ends. Secure Harness out of sight using cable ties, if needed.

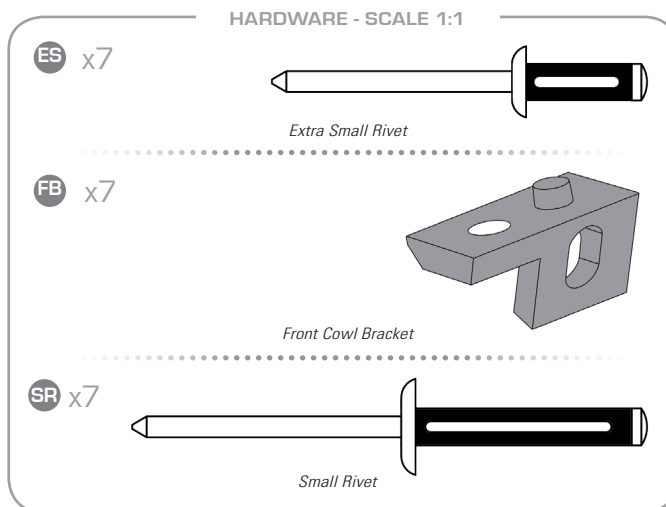

INSTALL OPTIONAL SENTRY DASH (Skip to step 7 if using factory dash)

STEP 6.1 INSTALL THE STEERING COLUMN COVER (OPTIONAL STAINLESS STEEL COVER)

- Reinstall the black plastic Factory Steering Column Cover on the Steering Column by simply sliding it over the Steering Column. **OR**, if you have an **Optional Stainless Steel Steering Column Cover**, install it now:
- Slide Steering Column Cover over the Steering Column so that it is flush with the front edge of the Steering Column. With a Punch, mark a drill-ready hole on the top of the Cover between 1/4" to 1/2" from the top of the Steering Column.
- Use a 1/8" drill bit to drill hole into the Steering Column Cover and Steering Wheel Column.
- use a #10 Set Screw to secure the Steering Column in place to prevent the Column Cover from rotating.

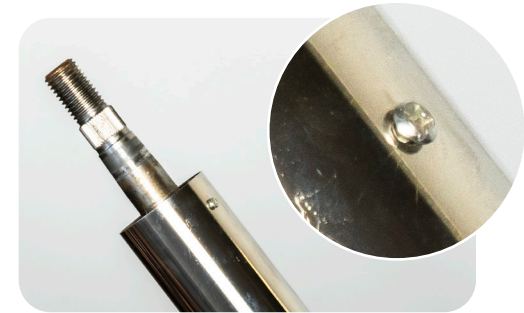

STEP 6.2 DRILL ACCESS HOLE FOR TURN SIGNAL WIRING

- Drill an approximately 1/2" hole in the side of the Center Console of Dash, for the Turn Signal wiring.
- **Make sure the hole connects to opening for the steering column.**



STEP 6.3 PLACE DASH & TURN SIGNAL WIRING INTO POSITION

- Feed the Turn Signal Connector and attached Flasher through the opening for the Steering Column and slide the Dash over the Steering Column and into position.
- Turn Signal wiring should fit neatly into the hole drilled in previous step. Connect the Turn Signal to the Dash Harness inside the Dash Center Console.



STEP 6.4 SECURE DASH TO FRONT COWL

- Make sure Dash is fully seated over Front Cowl and against Dash Frame, and secure with screws (DS x7).



DS x7

HARDWARE - SCALE 1:1

#8 x 3/4" Screw

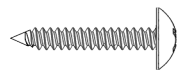

STEP 6.5 INSTALL DASH FACEPLATE

- Remove protective film from Faceplate.
- Install Faceplate with provided screws.
- Determine locations for Key Switch and 3-Position Light Switch. Drill holes in Faceplate to fit each Switch.

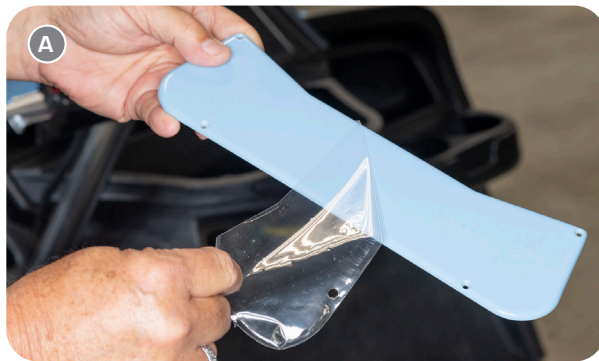

STEP 6.6 CONNECT THE POWER RELAY

- Connect the Dash Harness four Spade Connectors to the Relay, which controls Brake Light functionality.

• The simple connection rule is: **Small Spades to Small Ports** and **Large Spades to Large Ports**.

****Never use the middle inside Large Port.****

Connect in the following order:

- Yellow Wire/Small Spade to either Small Port
 - Black Wire/Small Spade to either Small Port
- Blue Wire/Large Spade to either Large Port
 - Green Wire/Large Spade to either Large Port

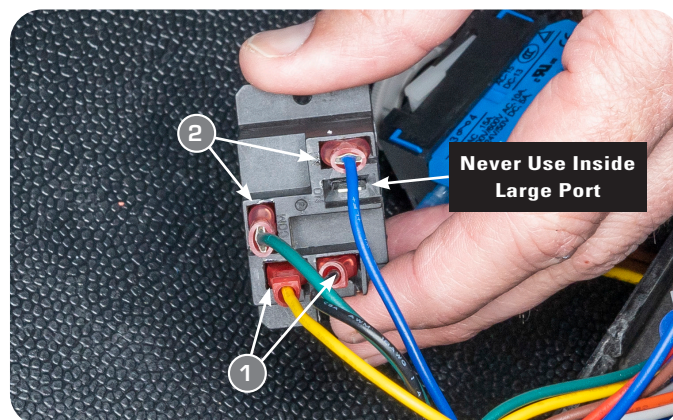

STEP 6.7 INSTALL 3-POSITION LIGHT SWITCH AND KEY SWITCH

- Remove the 3-Position Knob from Light Switch Body by pressing the white lever on top and pulling Knob out.
- Remove the Plastic Nut from Knob shaft.
- Insert 3-Position Knob through hole in Faceplate and secure with Plastic Nut. Reconnect Light Switch Body by pressing on white lever and reinstall over Knob shaft.
- Reinstall the Key Switch and reconnect wires.

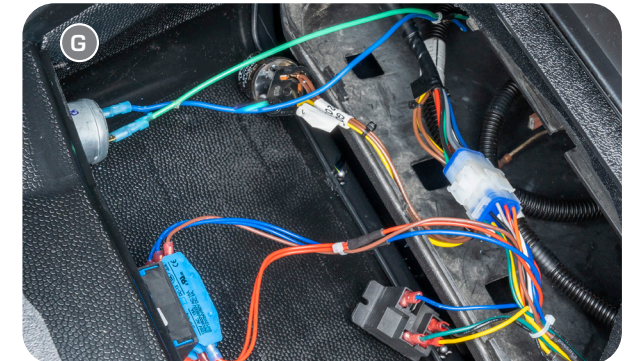
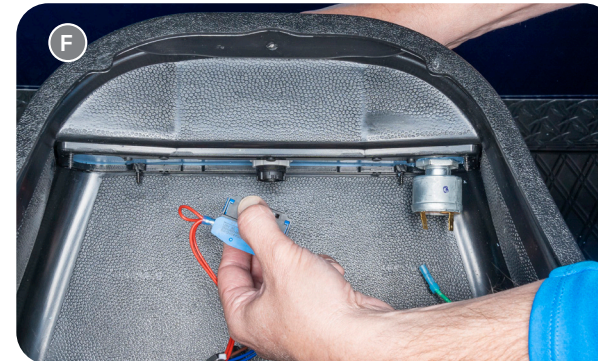
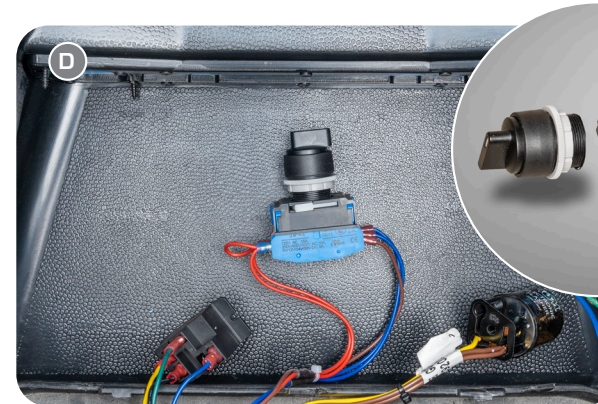

STEP 6.8 INSTALL COLORED DASH TRIM INSERTS

- Make sure the Dash surface is clean and free of dust and grime. Remove backing from adhesive strips on the back of Dash Trim Inserts and press into position. Firmly press the Trim Inserts in place for 30-45 seconds. Remove protective film from Dash Trim Inserts.
- Install Dash Console Tray using the 4 screws taped inside lid.



INSTALL REAR BODY

STEP 7.1 POSITION REAR BODY

- Place the Rear Body into position and make sure it is fully seated.
- Pull the Tail Light wiring connectors out of the Tail Light Holes.

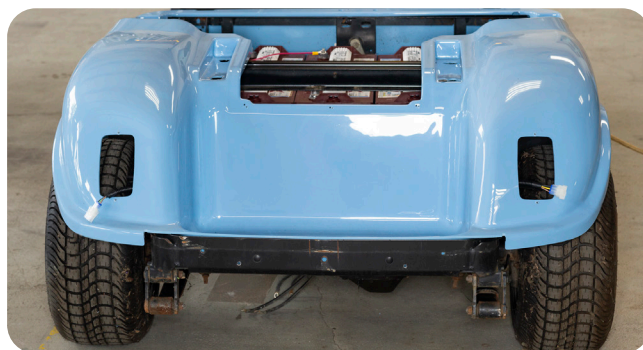

STEP 7.2 RIVET REAR BODY TO FLOOR

- Remove the protective film from Body around installation area.
- Attach the Rear Body to floor using Small Rivets (SR x4).
(*Note: Optional Diamond Tread Kick Plate shown on Body)



STEP 7.6 INSTALL CUSHION HINGES AND CHARGING RECEPTICLE

- Remove the protective film from Body around installation area.
- On the top front of the Rear Body there is a set of three holes on each side. Use the center hole of each set to attach the Body to the frame using Small Rivets (SR x2).
- Use the two remaining holes to install the Cushion Hinges using Small Rivets (SR x4).
- Reinstall the Charging Recepticle using Small Rivets (SR x4).

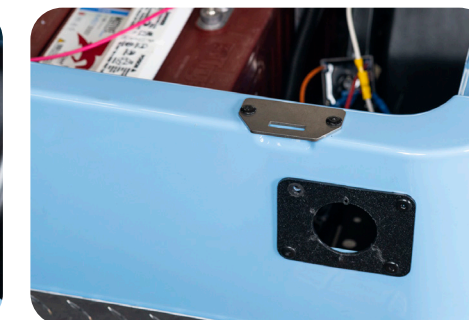

STEP 7.3 REINSTALL FLOOR MAT

- Reinstall the Floor Mat over the Rear Body edge that is attached to floor.



STEP 7.4 RIVET BODY IN BAGWELL

- Remove the protective film from Body around installation area.
- Attach Body to Chassis in the Bagwell through the two smallest holes (Larger holes are for water drainage) using Small Rivets (SR x2).



STEP 7.7 INSTALL TAIL LIGHTS

- Remove the protective film from Body around installation area.
- Connect the Tail Lights and install with provided screws.



STEP 7.5 INSTALL SIDE SUPPORT BRACKETS

- Remove the protective film from Body around installation area.
- Orient the Side Support Bracket so that it angles outward at the top. Use Small Rivets (SR x4) to attach Bracket to Chassis and to Rear Body.

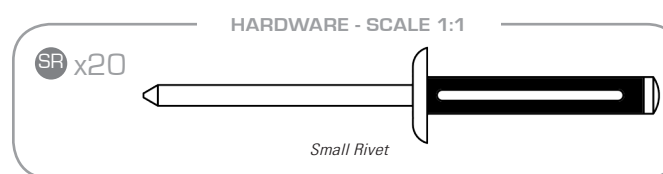

INSTALL OPTIONAL PILOT STEERING WHEEL (Skip to step 9 if using factory)

STEP 8.1 INSTALL HUB ADAPTER

- Install Steering Wheel Hub Adapter by sliding onto center cog and reinstalling the nut from removed the factory Steering Wheel.



STEP 8.3 INSTALL MAIN ACCENT

- Place Main Accent into Steering Wheel Base. Flip Steering Wheel over and insert screws to secure Main Accent and insert Black Screw Caps.



STEP 8.2 INSTALL TURN SIGNAL

- Slide Rubber Gasket onto Ring Clamp. Insert Ring Clamp through the slots on Turn Signal.
- Mount Turn Signal to Steering Column at desired location using the Ring Clamp.



STEP 8.4 INSTALL STEERING WHEEL

- Press the Center Cap Assembly onto the Steering Hub Adapter by aligning the grooves in the Center Cap Assembly with the holes in the Steering Hub Adapter.
- Press the Steering Wheel onto the Center Cap Assembly and check the hole alignment. Using the six hex socket bolts, attach the Center Accent and Steering Wheel to the Steering Hub Adapter. Tighten all bolts in an alternating pattern.



FINAL ASSEMBLY

STEP 9.1 CONNECT LIGHTS TO BATTERIES - **WARNING: Do not connect Lights to more than 16v or damage will occur**

See Diagrams below for connecting the Light Kit Harness to either a 36v or 48v system. After connecting Harness to batteries, proceed to test:

- Headlights • Turn Signals (front & rear) • Tail Lights • Brake Lights
- Delayed Brake Light (Park/Shutoff 30-45 sec delay) • Horn

E-Z-GO TXT - 48v (6 x 8v) and 36v (6 x 6v): Light Kit Harness Power Connection

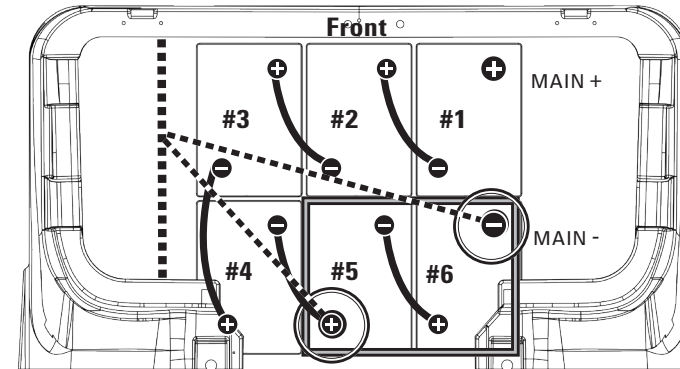

- A Voltage Reducer is recommended (Utilizes full battery bank and reduces 48v or 36v down to 12v for electronics)
- If you choose not to use a Voltage Reducer, **DO NOT connect Lights to more than 16v (2 batteries)**
- Connect Bucket Harness Negative (White) to Battery #6 Negative (Main)
- Connect Bucket Harness Positive (Red) to Battery #5 Positive

STEP 9.2 REINSTALL REMAINING FACTORY PARTS

- Reinstall the Side Rocker Panels using Large Rivets (LR x2).
- If installing a Rear Seat Kit, follow the provided instructions and install now.
- Reinstall Rear Bumper (if not installing a Rear Seat Kit), Front Frames, Top, Seat Cushions.

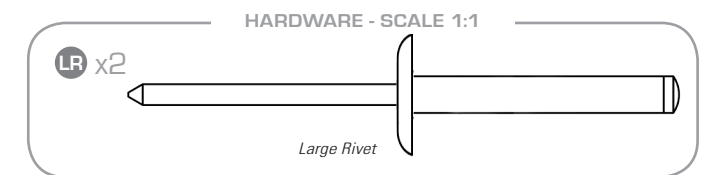
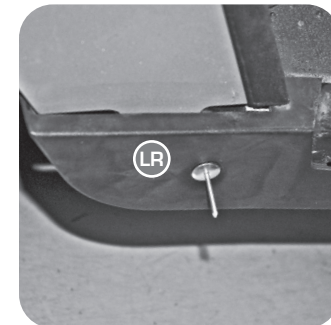



(This page left blank intentionally)